

33.713

Addit bobina mangiacavo ø15 mm/25 m 713

Un'ottima soluzione per ordinare i cavi di alimentazione e segnale. È sufficiente raggruppare manualmente i cavi, usare l'utensile inseritore della bobina mangiacavo e inserire i cavi attraverso la bobina. Gli utensili inseritori devono essere ordinati separatamente.

- Consente di risparmiare tempo e fatica
- Facile da installare con l'apposito utensile inseritore
- Dimensioni (\varnothing x l): 15 mm x 25 m
- Adatto per 3 cavi con 7 mm di spessore

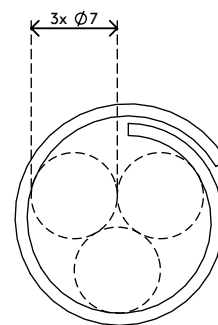
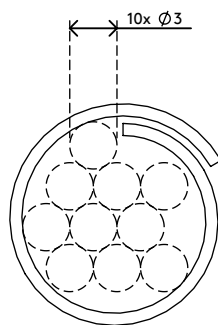
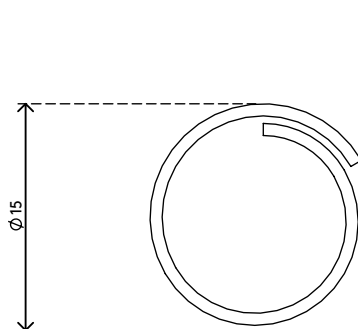
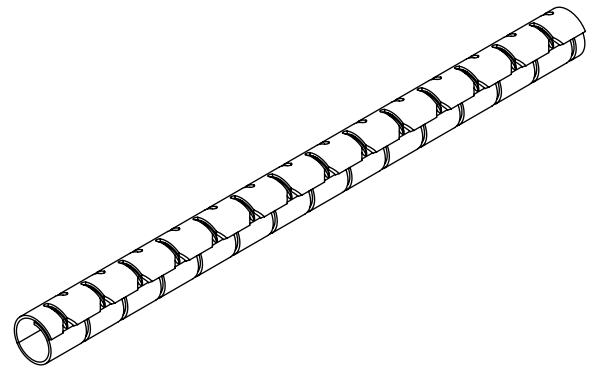
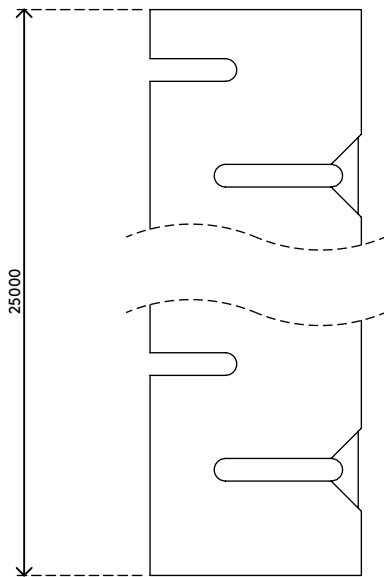

Addit bobina mangiacavo ø15 mm/25 m 713

2020/10/07

33.713

 430 x 315 x 165 mm

 1 pcs

 nero

 1,45 kg

 805410337131