

52.500

Addit pied support écran 500

Un moyen pratique, facile et abordable de profiter au mieux de votre écran. Remplacez votre support fourni avec l'écran par ce pied support écran en acier solide. Vous pouvez régler votre écran en hauteur, l'incliner et même le faire pivoter pour commuter entre le mode portrait et le mode paysage.

- Pour 1 écran jusqu'à 15 kg
- Compatible VESA MIS-D 75 x 75/100 x 100 mm
- Encombrement 250 x 202 mm
- Fabriqué en acier

- Hauteur réglable de 240 à 385 mm
- Écran: s'incline à +55°/-55°, tourne à 360°
- Relève un écran jusqu'à 100 mm en plus par rapport à la plupart des pieds d'écran

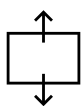
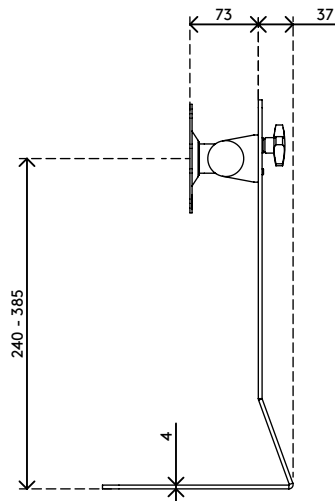
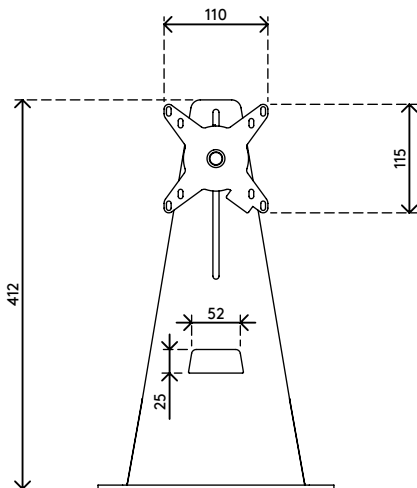
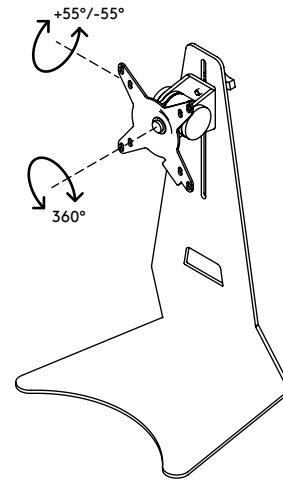
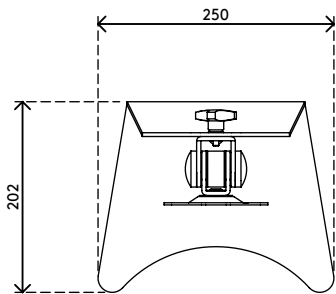

145 mm (5,7")



+55°/-55°



360°



770 mm (30,3")



75 x 75/100 x 100



15 kg

Addit pied support écran 500

2020/05/28

52.500

 265 x 230 x 475 mm

 1 pcs

 blanc

 3,73 kg

 805410525002